



**BQ2205**  
**BQ2208**  
**BQ2212**



**BQ2205E**  
**BQ2208E**  
**BQ2212E**

---

# **MARINE WATER HEATER WITH DUAL HEATING: ELECTRICAL HEATING AND INDIRECT HEATING**



**INSTRUCTION MANUAL**

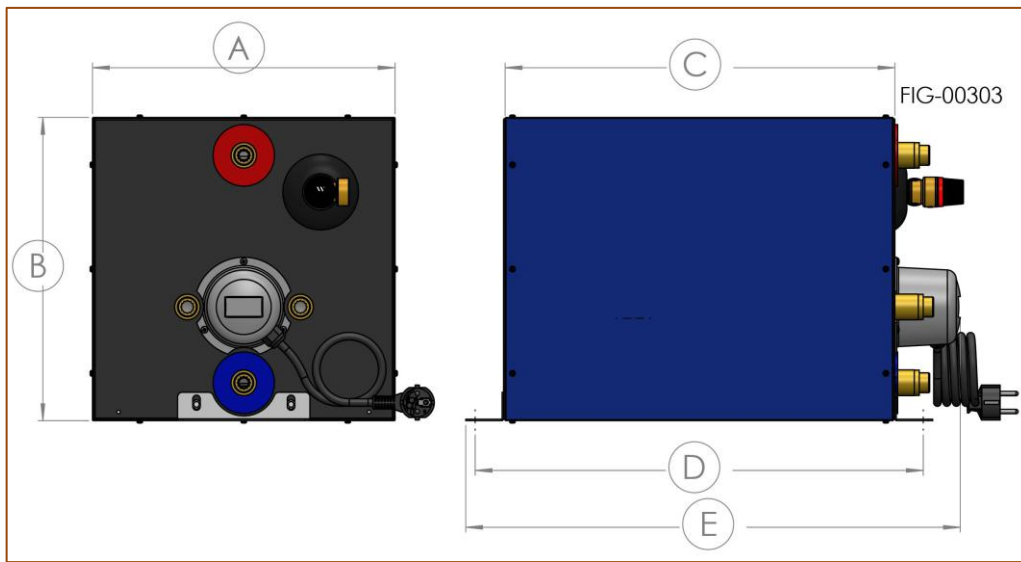

**FIG\_04-1**

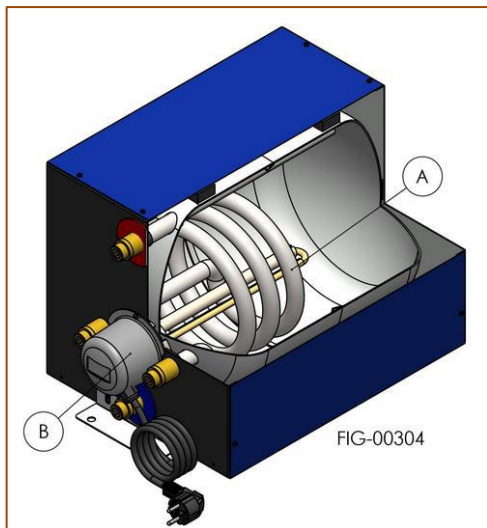

**FIG\_05-1**

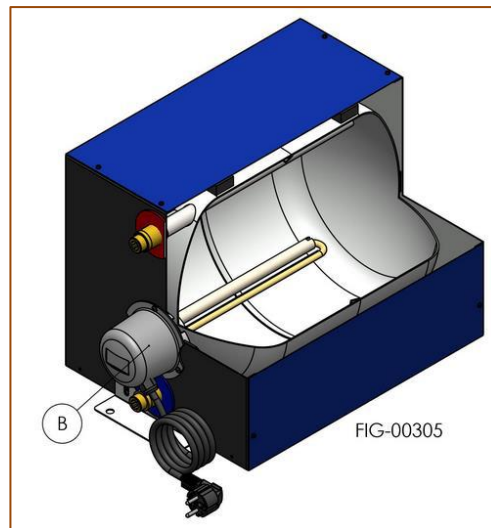

**FIG\_05-2**

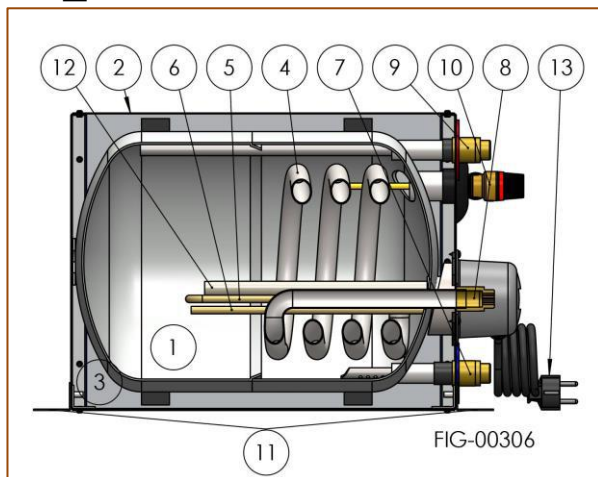

**FIG\_05-3**

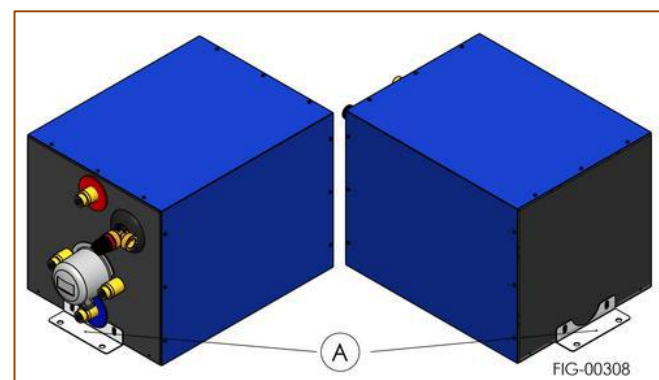

**FIG\_07-1**

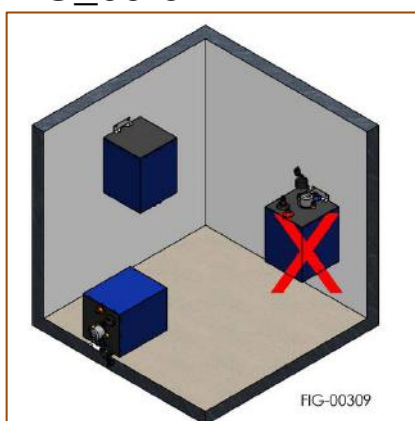

**FIG\_07-2**

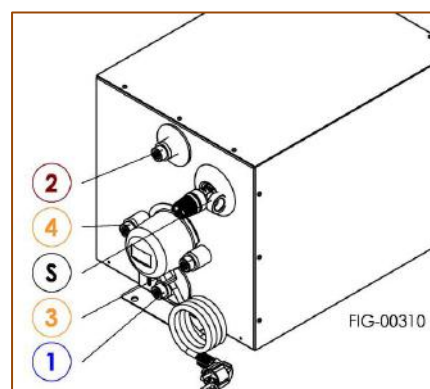

**FIG\_08-1**

This water heater has been designed and produced to ensure long and trouble free operation for many years. Every single water heater is individually pressure tested prior to delivery.

## 1. GENERAL PRECAUTIONS IMPORTANT SAFETY

To reduce the risk of fire, electric shock, or injury when using the appliance, carefully follow these basic precautions:

- ⚠ Read all instructions before installing and using the appliance. This manual is an integral and essential part of the device: it must be kept on hand for future reference.
- ⚠ Use the water heater in the applications described in this manual. Do not use this device for other types of operations
- ⚠ The installation must be performed by a qualified person who is responsible for the implementation of existing security standards. Improper installation, caused by failure to follow the manufacturer's instructions, may cause injury to persons, animals or damage to other equipment for which the manufacturer assumes no responsibility
- ⚠ The appliance must not be installed in environments with excessive presence of water and must be protected from splashing water, jets of water or other liquids, in order to avoid short circuits.
- ⚠ This device is not intended for use by persons (including children) with reduced physical sensory or mental capabilities, or lack of experience and knowledge, unless they are given supervision or instruction for use of the appliance by a person responsible for their safety.
- ⚠ Children being supervised not to play with the appliance.
- ⚠ Do not clean appliance parts with flammable fluids and do not store or use gasoline or other flammable vapors and liquids in the vicinity of this. Gases and vapours can create a fire hazard or explosion.
- ⚠ The packaging material (plastic bags, foam, clips, etc.) must be kept away from children, because they can be dangerous.
- ⚠ If the appliance is sold to another owner, make sure that this booklet stays with the appliance so that the new owner and / or installer can consult it

## 2. SPECIFICATIONS

P/N		supply	power	power	capacity	max pressure	weight empty	weight filled
		V~	A	w	lt (gal)	kPa (psi)	Kg (lb)	Kg (lb)
BQ2205	BOAT BOILER BQ 22 lt - 550 W - 230 V	230	2,4	550	22 (5,8)	700 (102)	14 (31)	36 (79)
BQ2208	BOAT BOILER BQ 22 lt - 850 W - 230 V	230	3,7	850	22 (5,8)	700 (102)	14 (31)	36 (79)
BQ2212	BOAT BOILER BQ 22 lt - 1250 W - 230 V	230	5,4	1250	22 (5,8)	700 (102)	14 (31)	36 (79)
BQ2205E	BOAT BOILER BQ 22 lt - 550 W - 230 V - no coil	230	2,4	550	23 (6,0)	700 (102)	12 (27)	34 (75)
BQ2208E	BOAT BOILER BQ 22 lt - 850 W - 230 V - no coil	230	3,7	850	23 (6,0)	700 (102)	12 (27)	34 (75)
BQ2212E	BOAT BOILER BQ 22 lt - 1250 W - 230 V - no coil	230	5,4	1250	23 (6,0)	700 (102)	12 (27)	34 (75)

## 3. PACKAGING

The device is packaged and delivered in a cardboard box with adequate protection. In addition the apparatus, inside the box is present the installation manual.

## 4. DIMENSIONS (FIG\_04-1)

A	B	C	D	E
mm (")	mm (")	mm (")	mm (")	mm (")
320 (12,6)	320 (12,6)	410 (16,1)	460 (18,1)	523 (20,6)

## 5. CONSTRUCTION DESCRIPTION AND OPERATION

The purpose of this device is to heat the sanitary hot water in two different ways (see FIG\_5-1 for mod. BQ22XX, FIG\_5-2 for mod. BQ22XXE):

- A. Through the heat exchanger (only model BQ22XX) between the engine cooling water and the water stored in the tank. Such heat exchange is possible thanks to a heat exchanger. The engine cooling water circulates through a coil placed at the center of the tank to spread the heat evenly.
- B. By means of an electric resistance (supplied as standard with the appliance).



**Main parts (see FIG\_5-3):**

1. Storage tank: it is entirely made of steel submitted internally to a double enamelling treatment that is a vitreous coating cooked at over 850 °C;
2. External coating in aluminum: it is highly resistant to shocks and external solicitations, having at the same time a very pleasant design;
3. Thermal insulation: made of expanded polyurethane with closed cells avoids unnecessary heat losses. In this way the heat loss by thermal inertia is reduced to 1 ° C per hour for a period of 24 hours;
4. Heat exchanger (only models BQ22XX): it is made of enamelled iron and its exchange surface allows to exploit at best the heat of the engine cooling water and to get hot water also in extreme conditions (very small temperature differences);
5. Electrical resistance: the device is equipped with an electric heating element to heat the water even when the boat engine is turned off (for example when the boat is on the dock). Material: Incoloy corrosion resistant alloy.
6. Thermostat: has two functions, namely:
  - a. Temperature control: it interrupts the power supply to the heater element when reaching the set temperature
  - b. Overtemperature safety: it interrupts the power supply to the resistance in case of excessive water temperature.

Thermostat characteristics: temperature control 0-60 °C; differential temperature about 9 ° C; intervention temperature 83 ° C; maximum current 16 A;
7. Cold water inlet;
8. Heat exchanger connection (only model BQ22XX);
9. Hot water outlet;
10. Safety of combined temperature and pressure relief valve protects the tank from possible excessive pressures caused by the expansion of water during heating. Automatically, without the assistance of different energy from that of the hot fluid under pressure, discharge a quantity of fluid such as to prevent them from being exceeded the predetermined pressure and temperature limits to protect the storage tanks. Calibration: 700 kpa / 99 ° C;
11. Mounting brackets;
12. Magnesium sacrificial anode: prevents corrosion of the tank;
13. Power supply cable with schuko plug.

## 6. GENERAL WARNINGS

- The installation must be performed in accordance with current legislation, by a qualified person who can do, not only a proper set up of the device, but also the necessary tests before starting the water heater.
- During the original installation and subsequent maintenance, follow the instructions in this booklet carefully. Changes to any type of connection or failure to follow instructions will cause the warranty expires.
- Before the installation, maintenance or repair, remove the power supply unit.



**WARNING: USE THE BOILER ONLY FOR APPLICATIONS IN THIS SECTION. DO NOT USE THIS EQUIPMENT FOR OTHER TYPES OF OPERATION. THE BUILDER IT ASSUMES NO RESPONSIBILITY FOR INCIDENTAL OR CONSEQUENTIAL DAMAGES CAUSED BY IMPROPER APPLIANCE.**

## 7. POSITION AND ASSEMBLY

The appliance is equipped with two fixing brackets (A - FIG\_7-1). In this way we get an easy, but fixed and stable installation. The device must be installed horizontal or in such a way that the heat exchanger and / or the electrical resistance are placed in the lower part (FIG\_7-2).

The unit can be installed in any room, without any restrictions. The above does not exempt from complying with the instructions provided in the section "General precautions" at the beginning of this booklet.

For other installation not covered in this manual and for installation on sloped walls contact our technical department.

## 8. HYDRAULIC CONNECTIONS

To extend the life of the appliance water quality must meet the following parameters:

- |  |  |
|--|--|
| 1. hardness comprised between 15 and 50 ° F (in particular, where the water has undergone a softening or desalination treatment) | 2. chlorides comprised between 25 and 100 mg / l |
|  | 3. PH between 6.5 and 9.5                        |
|  | 4. conductivity between 400 and 1500mS / cm      |

Minimum pressure water inlet: 70 kpa.

Maximum water inlet pressure: 750 kpa (for higher inlet pressures is necessary to mount a pressure reducer with compensation of inlet pressure; adjustable downstream pressure, max 700 kpa)

Connect the appliance according to the following directions:

### Connections (FIG\_8-1):

1. cold water inlet	1/2 "
2. hot water outlet	1/2 "
3. Water supply to the engine cooling circuit	1/2 "
4. return water from the engine cooling circuit	1/2 "

### Plant scheme (FIG\_8-2):

- A. sanitary water tank
- B. pump
- C. pressure reducer
- D. non-return valve
- E. water heater
- F. engine cooling circuit



**MAX TEMPERATURE OF RETURN WATER FROM THE ENGINE COOLING CIRCUIT : 65 °C**

It is recommended to insulate the hot water pipes in order to avoid unnecessary waste of energy.

The device is equipped with combined temperature and pressure relief valve (calibration: 700 kpa / 99°C) : it protects the tank from possible excessive pressures caused by the expansion of water during heating.

Upon the occurrence of this situation, the water is discharged through the outlet of which is equipped with the valve (S - FIG\_8-1). Caution: connect the water drain valve to a rubber tube



**PIPE CONNECTED TO DISCHARGE VALVE MUST NOT BE SEALED OR LOCKED, MUST BE INSTALLED WITH A CONSTANT INCLINE DOWN AND PROTECTED BY ICE. IT MUST NOT BE CONNECTED TO A TAP AND MUST BE KEPT CONSTANTLY FREE OF OBSTRUCTION**

## 9. ELECTRICAL CONNECTIONS

The apparatus It must be connected to a single-phase power supply (please pay attention to connect the correct voltage according to the data present on the label) and to an effective ground connection.



**CAUTION: BEFORE MAKING THE CONNECTION, MAKE SURE THE POWER IS COMPLETELY DISCONNECTED. THE BUILDER DOES NOT ACCEPT RESPONSIBILITY FOR POSSIBLE DAMAGE CAUSED BY FAILURE OF THE APPLIANCE BE GROUNDED**

The apparatus is equipped with a power cord with plug. Plug the power cord in accordance with the wiring regulations in force in the country where the equipment is installed.

If the use of the safety plug it is not necessary it's possible to cut the power cord and connect it to a different plug or directly to the supply connection (this operation can be performed only by authorized personnel).

If the supply cord is damaged, it must be replaced by the manufacturer, its service agent or similarly qualified persons in order to avoid a hazard

In case of replacement of the power cord, use only a cable with the same characteristics: H05 VV-F - 3G 1.5 mm<sup>2</sup>

Be careful in properly connect the polarities (FIG\_9-1):

L → phase (brown wire)

N → neutral (blue cable)

The electrical system a bipolar switch must be installed to turn on and off the device and a fuse of suitable rating. The connections to the mains must be made in accordance with the national standards of electrical installations.



**WARNING: CONNECT THE POWER TO THE ELECTRIC HEATER ONLY WHEN THE TANK IS FULL OF WATER. THE HEATING ELEMENT IS NOT SUITABLE FOR OPERATION DRY**

## 10. SETTING THE WATER TEMPERATURE

On the electrical resistance there is a thermostat, which interrupts the power supply when the preset temperature is reached.

Setting the temperature (T - FIG\_09-1): it is possible to adjust the hot water temperature between 0 ° C and 60 ° C, according to the user's needs. The thermostat regulates the water temperature in the operation exclusively with electrical resistance.



**WARNING: BEFORE WORKING ON THE THERMOSTAT, MAKE SURE THE POWER IS COMPLETELY DISCONNECTED**



## 11. MAIN PARTS (FIG\_11-1)

POS.	COD.	DESCRIPTION	pcs
01	0-0618	fixing-mounting bracket	2
02	020-0052	heating element cap	1
03	100-0086	gasket	1
04	130-0134	1/2" BSP extension fitting	4
05	130-0059	T&P valve	1
06	140-0001	cable gland	1
07	280-0014	heating element 230 V - 550 W (mod. BQ2205)	1
07	280-0015	heating element 230 V - 850 W (mod. BQ2208)	1
07	280-0016	heating element 230 V - 1250 W (mod. BQ2212)	1
08	280-0042	thermostat	1
09	900-0135	power cable with plug	1

## 12. INTERVENTION WATER SAFETY

The electrical resistance is equipped with a thermostat which also has safety function: it interrupts the power supply to the resistance in case of excessive water temperature.

In the event of such a condition to start again the appliance, it is necessary a manual intervention (manual reset).



**DANGER: THE OPERATION OF THE THERMAL CUT-OUT INDICATES A POSSIBLY DANGEROUS SITUATION. DO NOT RESET THE THERMAL CUT-OUT UNTIL THE WATER HEATER HAS BEEN SERVICED BY A QUALIFIED PERSON**

For the manual reset operation, proceed as follows:

- Disconnect the power supply;
- Remove the electrical resistance of the protective cover (FIG\_14-1);
- Press reset button positioned on the thermostat (R - FIG\_9-1);
- Mount of electrical resistance protective cover;
- Restore power supply;

## 13. SAFETY VALVE INTERVENTION

The device is equipped with a combined safety valve (temperature and pressure): it protects the tank from possible excessive pressures caused by the expansion of water during heating. Upon the occurrence of this situation, the water is discharged through the outlet of which is equipped with the valve.

A small amount of water may come out from this exhaust during the step of heating water.



**CONTINUOUS LEAKAGE OF WATER FROM THE VALVE MAY INDICATE A PROBLEM WITH THE WATER HEATER. FAILURE TO OPERATE THE RELIEF VALVE EASING GEAR AT LEAST ONCE EVERY SIX MONTHS MAY RESULT IN THE WATER HEATER EXPLODING.**

## 14. MAINTENANCE OF THE APPLIANCE

To make ensure safe operation and extend its life, it recommends regular inspection (at least annually) by the authorized customer service or by suitably qualified personnel

Recommended operations during the periodic inspection:

- Sealing the plumbing fittings;
- Failure to fully loosen the safety valve;
- Fastening occurs (replace the fastening screws in case they are worn);
- Electrical system efficiency and electrical grounding;**
- Conditions of the power cable (if it is damaged it must be replaced by the manufacturer, authorized technical service or by qualified personnel in order to avoid risks);
- The pressure-relief device is to be operated regularly to remove lime deposits and to verify that it is not blocked;
- Yearly replacement of the anode, otherwise the right to the warranty will be lost (FIG\_11-1);

To avoid damage caused by frost during the cold season, in the case the boiler is not used, it is necessary to completely empty the apparatus.

## 15. WARRANTY

The warranty terms are valid provided that the installation instructions contained in this booklet are followed. The warranty begins on the information printed on the label the date of manufacture of the device and has a duration of 36 months. For safety reasons and for the validity of the guarantee it is mandatory to use only original spare parts.

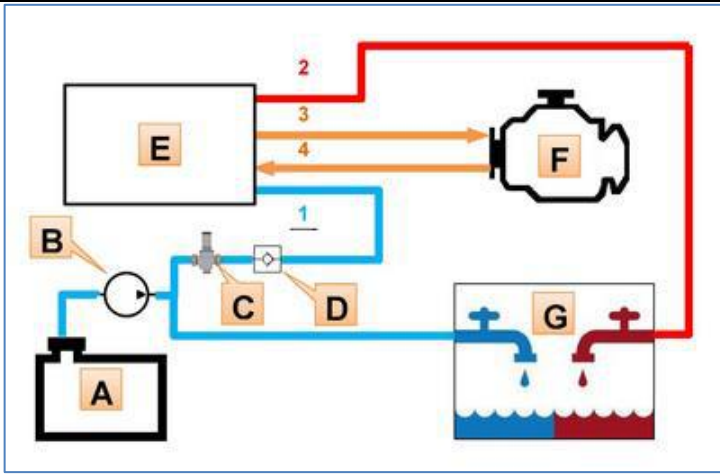

FIG\_08-2

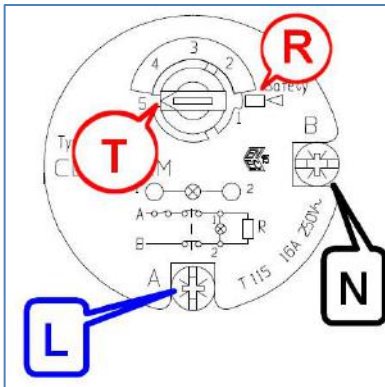

FIG\_09-1

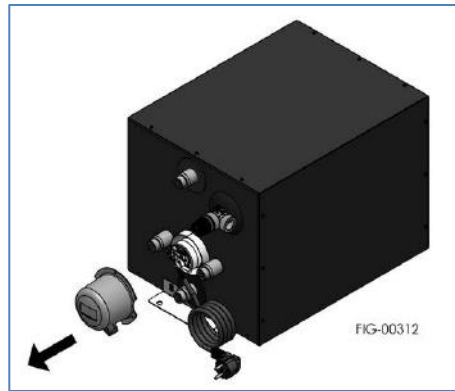

FIG\_14-1

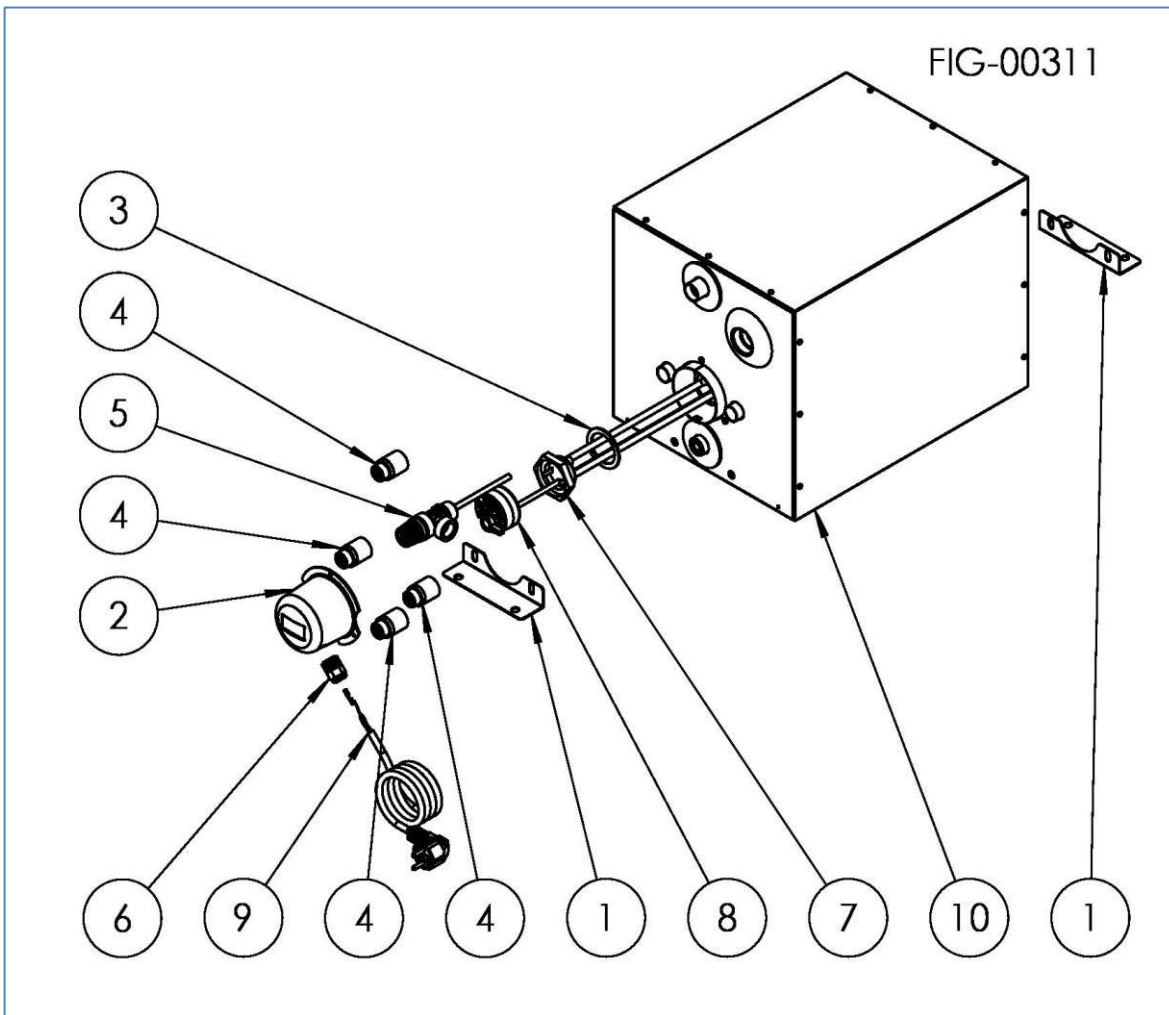

FIG\_11-1



# ATI DI MARIANI SRL

Via E. Mattei 461  
Zona Ind. Torre del Moro n°4  
47522 Cesena (FC) - ITALIA

Tel. +int-39-0547 609711  
Fax +int-39-0547 609724

[www.nautica.atimariani.it](http://www.nautica.atimariani.it)

[nautica@atimariani.it](mailto:nautica@atimariani.it)